

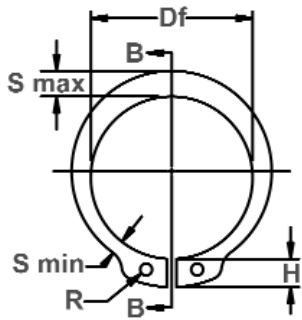

MSR Shaft Rings

Axially Assembled, External Reinforced, ANSI Metric

The MSR is an extra thick version of a regular MSH retaining ring. As such, it is stronger and can withstand greater thrust loads than its standard counterpart.



Free Diameter & Ring Measurements With Section B-B

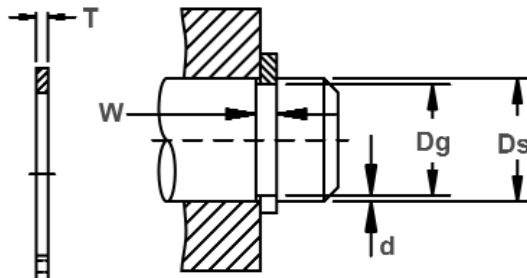

Shaft Diameter & Groove Dimensions

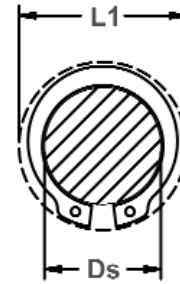

Clearance Diameter Expanded Over Shaft

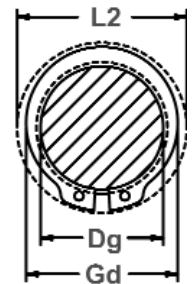

Clearance Diameter & Gaging Diameter Released In Groove

RING NO.	SHAFT DIAMETER		GROOVE SIZE					RING SIZE & WEIGHT					CLEARANCE DIA.			THRUST LD (kN.)	
			DIAMETER		WIDTH		DEPTH	FREE DIAMETER		THICKNESS***			Wt. Per 1000 pcs.	Ex-panded over Shaft	Re-leased in Groove	Sqr. corner abutment	
	Ds mm	Ds INCH	Dg	tol	F.I.M.*	W	tol	d	Df	tol	T	tol				kg	L1
MSR-10	10	0.393	9.40		0.05	1.00		0.30	9.20	+0.08	0.9		0.32	15.6	14.8	9.3	2.9
MSR-11	11	0.433	10.30	-0.08	0.05	1.00		0.35	10.00	-0.20	0.9		0.39	16.6	15.8	10.8	3.8
MSR-12	12	0.472	11.30		0.05	1.20		0.35	11.05		1.1		0.63	17.6	16.8	13.7	4.0
MSR-13	13	0.512	12.20		0.05	1.40		0.40	11.80		1.3	±0.06	0.72	19.5	18.5	17.6	5.0
MSR-14	14	0.551	13.15		0.05	1.40	+0.15	0.43	12.80		1.3		0.80	20.5	19.5	18.9	5.8
MSR-15	15	0.591	14.10		0.05	1.40		0.45	13.80		1.3		1.00	22.1	21.1	20.3	6.5
MSR-16	16	0.630	15.00		0.08	1.40		0.50	14.70	+0.13	1.3		1.04	23.2	22.0	21.6	7.7
MSR-17	17	0.669	15.95	-0.10	0.08	1.40		0.53	15.65	-0.25	1.3		1.2	24.2	22.9	23.0	8.7
MSR-18	18	0.708	16.85		0.08	1.75		0.58	16.55		1.6		1.9	26.8	25.5	30.0	10.0
MSR-19	19	0.748	17.80		0.08	2.15		0.60	17.50		2.0		2.5	28.8	27.4	40.0	11.0
MSR-20	20	0.787	18.75		0.08	2.15		0.63	18.45		2.0		2.8	29.8	28.4	42.0	13.1
MSR-22	22	0.866	20.70		0.08	2.15		0.65	20.40		2.0		3.4	31.9	30.4	46.0	13.7
MSR-25	25	0.984	23.50		0.08	2.15		0.75	23.10		2.0		3.5	34.9	33.1	52.0	18.0
MSR-27	27	1.063	25.40		0.10	2.55		0.80	24.85		2.4		5.2	39.0	37.1	67.0	20.8
MSR-28	28	1.102	26.30		0.10	2.55		0.85	25.70		2.4	±0.08	5.6	40.0	38.0	69.0	22.8
MSR-30	30	1.181	28.20	-0.15	0.10	2.55	+0.20	0.90	27.60	+0.25	2.4		6.1	42.0	40.0	74.0	26.0
MSR-32	32	1.260	30.00		0.10	2.55		1.00	29.35	-0.40	2.4		6.8	44.1	41.8	79.0	30.8
MSR-35	35	1.378	32.80		0.10	2.55		1.10	32.20		2.4		8.1	47.1	44.6	87.0	38.0
MSR-38	38	1.496	35.60		0.10	2.95		1.20	35.05		2.8		12.2	53.2	50.5	111.0	44.0
MSR-40	40	1.575	37.50		0.15	2.95		1.25	36.70	+0.35	2.8		14.1	55.2	52.4	116.0	48.0
MSR-45	45	1.772	42.20	-0.20	0.15	2.95		1.40	41.10	-0.50	2.8		15.1	60.9	57.7	130.0	61.0
MSR-50	50	1.969	47.00		0.15	3.40	+0.25	1.50	45.50		3.2	±0.10	21.8	67.1	63.8	165.0	72.0

* F.I.M.(FULL INDICATOR MOVEMENT)-MAXIMUM ALLOWABLE DEVIATION OF CONCENTRICITY BETWEEN GROOVE AND SHAFT.

† BASED ON HOUSINGS/SHAFTS MADE OF COLD ROLLED STEEL. FOR AN EXPLANATION OF FORMULAS USED TO DERIVE THRUST LOAD AND OTHER PERFORMANCE DATA, CONTACT THE ROTOR CLIP ENGINEERING DEPARTMENT.

*** FOR PLATED RINGS, ADD 0.05 TO THE LISTED MAXIMUM THICKNESS. MAXIMUM RING THICKNESS WILL BE A MINIMUM OF 0.005 LESS THAN THE LISTED GROOVE WIDTH (W) MINIMUM.

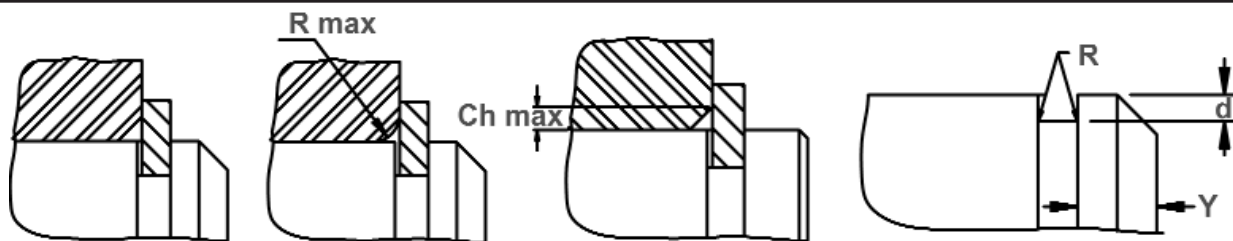

Square Corner Abutment

Allowable Corner Radius & Chamfer

Exploded Groove Profile & Edge Margin (Y)
 Maximum bottom radii (R), 0.10 for ring sizes
 -10 thru -15; 0.15 for ring sizes -16 thru -20;
 0.20 for ring sizes -22 thru -30
 0.30 for ring sizes -32 thru -50

RING NO.	LUG HEIGHT	MAXIMUM SECTION	MINIMUM SECTION	HOLE DIAMETER	GAGING DIA.	ALLOWABLE CORNER RADII & CHAMFERS		MAX. LOAD w/ R max or Ch max (kN)	EDGE MARGIN	R.P.M. LIMITS Standard Material
	H nom	S max	S min	R min	Gd	R max	Ch max	P'r	Y	RPM
MSR-10	2.6	1.7	1.0	1.0	12.15	1.0	0.8	2.7	0.9	66000
MSR-11	2.6	1.9	1.1	1.0	13.40	1.0	0.8	3.0	1.0	60000
MSR-12	2.6	2.2	1.3	1.0	14.95	1.6	1.3	3.2	1.0	55000
MSR-13	3.0	2.3	1.3	1.2	15.80	1.6	1.3	4.6	1.2	52000
MSR-14	3.0	2.4	1.4	1.2	16.90	1.6	1.3	4.8	1.3	47000
MSR-15	3.3	2.6	1.4	1.2	18.20	1.6	1.3	5.2	1.3	42000
MSR-16	3.3	2.7	1.5	1.2	19.20	1.6	1.3	5.4	1.5	39000
MSR-17	3.3	2.8	1.6	1.2	20.45	1.6	1.3	5.7	1.6	36000
MSR-18	4.1	3.0	1.8	1.9	21.75	1.8	1.5	8.0	1.7	35000
MSR-19	4.6	3.2	2.0	1.9	23.05	1.8	1.5	13.2	1.8	30000
MSR-20	4.6	3.4	2.0	1.9	24.30	2.0	1.6	13.2	1.9	29000
MSR-22	4.6	3.8	2.1	1.9	26.60	2.0	1.6	14.7	2.0	27000
MSR-25	4.6	3.8	2.1	1.9	29.45	2.0	1.6	14.7	2.2	24000
MSR-27	5.6	4.1	2.3	2.3	32.00	2.0	1.6	22.9	2.4	22000
MSR-28	5.6	4.3	2.4	2.3	33.20	2.0	1.6	24.0	2.5	20000
MSR-30	5.6	4.5	2.5	2.3	35.40	2.0	1.6	25.0	2.7	19000
MSR-32	5.6	4.7	2.6	2.3	37.30	2.5	2.1	19.0	3.0	18000
MSR-35	5.6	5.1	2.8	2.3	40.80	2.5	2.1	22.0	3.3	16000
MSR-38	7.1	5.5	3.1	2.7	44.40	2.5	2.1	32.0	3.6	15000
MSR-40	7.1	5.8	3.2	2.7	46.70	2.5	2.1	34.0	3.7	13500
MSR-45	7.4	6.5	3.6	2.7	52.20	2.5	2.1	38.0	4.2	12500
MSR-50	8.0	7.1	3.9	3.1	58.40	3.5	2.9	39.0	4.5	11000

LARGER SIZES MAY BE AVAILABLE UPON REQUEST.

HARDNESS RANGES: STAINLESS STEEL RINGS (PH 15-7MO)

RING TYPE	SIZE RANGE	SCALE	ROCKWELL HARDNESS
MSR	10-16	30N	63-69.5
	17-50	C	44-51

HARDNESS RANGES: CARBON STEEL RINGS (SAE 1060-1090)

RING TYPE	SIZE RANGE	SCALE	ROCKWELL HARDNESS
MSR	10-16	30N	68.5-72
	17-50	C	48-52